

JEROS Utensil Washers

Large and Powerful



Smarter Solutions

Unique to JEROS machines

The JEROS Utensil Washers have a unique lid construction and provide outstanding wash results in a very compact space that allows :

- ✓ Loading and emptying of the machine from 3 sides.
- ✓ Integrated water taps
- ✓ Same limited space requirement when opened or closed.

The JEROS wash frame -the unique wash system:

The moving wash frame has nozzles fixed on all 4 sides, encompassing the whole of the wash area, and guaranteeing the most efficient results and removal of the heaviest dirt.



JEROS 8120

Ideal for washing 2 standard sized crates and can also be used as a 'run through' washer, accommodating trays 98 x 58cm, 2 crates 60 x 40 x 41cm, or 2 gastronomy baskets 50 x 50cm, pots, pans, food containers etc.



Fulfil the highest hygiene standards

Even the most persistent dirt is removed! The fully automatic detergent dispenser ensures the optimum dosage of soap. Two powerful pumps and the moving wash frame provide a brilliant wash result. The end rinse pump guarantees a constant temperature of 85° C during the entire rinse period, ensuring complete sanitation of the utensils. Also, as a result of the high temperature rinse, fast drying of utensils is achieved. After the last wash process, the machine empties through the drain pump, and a self-cleaning programme is activated.

More than just a Utensil Washer

- ✓ Large wash volume.
- ✓ Brilliant wash result.
- ✓ Adjustable wash temperature.
- ✓ Self-cleaning programme with fresh 85° C hot water.
- ✓ Integrated mixer tap.
- ✓ Flush hose for external cleaning.









JEROS 8130

Compact in design, with the largest capacity!
Capable of washing 3 crates 60 x 40 x 41cm
or 21 trays 60 x 40cm in one wash cycle

There are a variety of reasons to choose a JEROS!



-  The robust stainless steel construction, established design, combined with more than 40 years of expertise, guarantees very high reliability.
-  The 85° C hot end rinse through a pressure pump ensures maximum hygiene is achieved.
-  Operating costs at a minimum with the sensor operated detergent dosing system and thermostatically controlled heating elements.
-  Adjustable wash pressure: The second wash pump can be de-activated for the washing of light items.
-  Standard features: Adjustable wash temperature, drain pump, automatic start, self-cleaning programme, micro-steering by finger touch control panel.
-  No matter who: Bakery, Confectioners, Butcher, Restaurants, Food Industry, or, or, or..... JEROS offers a suitable washer for all requirements!
-  Meets HACCP and CE-requirements.



Technical data		8120	8130
Drain dimension	Ø mm	40	40
Voltage	Volt+E/Hz	400 / PE / 50	400 / PE / 50
Connecting power (standart)	kW	16,5	17,5
Water connection	R"	1/2	1/2
Wash time	Min.	2 - 4 - 6	2 - 4 - 6
Wash area	HxWxD	645x1010x635	645x1290x635
Wash tank volume	Litre	95	125
Rinse time	apprx. sec.	15	20
Rinse tank volume	apprx. litre	13	25
Rinse water temperature	apprx. °C	85	85
Water consumption per wash/rinse	apprx. litre	8	12

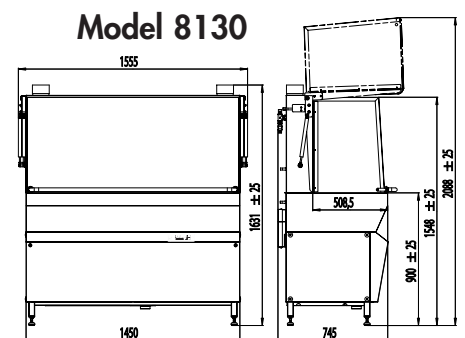
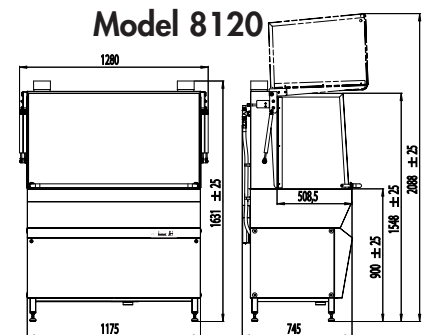

JEROS distributor:

Clean and happy..



JEROS INHOUSE - 03.2006
Technical specifications are subject to alteration.



JEROS A/S

Nyborgvej 8
DK-5750 Ringe

Tel: 0045 63 62 39 13
Fax: 0045 62 62 33 01

E-mail: jeros@jeros.dk
Http: //www.jeros.com